



## OWNER'S MANUAL E-BIKES NORTH AMERICA

---



---

# COPYRIGHT

---

Copyright 2017 RIESE & MUELLER GMBH

The information contained in this manual and/or any of its parts, sub-parts or chapters, is the intellectual property of RIESE & MUELLER GMBH and is protected by domestic and international copyright and other intellectual property laws.

The information contained herein is provided for the operation, service and troubleshooting of the product described herein.

Any duplication, reproduction, translation, micro filming, storage in electronic or magnetic form, processing as electronically or magnetically stored media, copying or dissemination of these materials and/or the information contained herein, or any part thereof, except for the internal use of RIESE & MUELLER GMBH or its authorized external suppliers, consultants or agents, without the prior written consent of RIESE & MUELLER GMBH, is hereby strictly prohibited.

All rights and remedies are hereby expressly reserved.

Violators will be prosecuted.

RIESE & MUELLER GMBH shall have no liability whatsoever arising from or connected in any way to the so prohibited use of the information contained herein by any person or entity, wherever located, for whatever reason.

RIESE & MUELLER GMBH reserves the right to change, delete or otherwise alter or modify any information contained herein, or the product itself, at any time and for any reason, with or without notice.



---

# IMPORTANT INFORMATION

---

This manual describes how to use your Riese & Müller E-Bike in a safe manner. It is essential that whoever owns or uses the E-Bike has read this manual before riding the E-Bike for the first time. This also applies to anybody who considers himself or herself to be an experienced bicycle rider. In some aspects E-Bikes substantially differ from regular bicycles.

There is an example illustration of an E-Bike (and an E-Cargo bike respectively) on either of the inner sides of this manual's cover describing the vehicle's most important components and parts. For easier navigation and reference we do recommend to leave these inner sides open while reading this manual.

This manual and all other included manuals for brakes, gears, suspension, electric drive and optional accessories are an integral part of the E-Bike.

Read all the manuals carefully. Store all manuals close to where you store your E-Bike to have them handy if questions arise.

In case this E-Bike is sold or given to another person as a gift or even only for temporary use, all manuals must be given as well.

This manual also describes simple do-it-yourself inspections for the E-Bike.

This manual, however, is no substitute for a complete workshop manual.

**All service and repair work on any Riese & Müller E-Bike shall always be performed only by an authorized dealer.**

In case anything in this manual is not clear or if you need further information regarding a function of the Riese & Müller E-Bike, please contact your authorized dealer or Riese & Müller customer service ([www.r-m.de](http://www.r-m.de), Tel. +49 6151-36686-0).

---

# SAFETY INFORMATION

---

Riding an E-Bike can be hazardous. Therefore, never overestimate your abilities or the capabilities of your E-Bike when riding it.

By riding an E-Bike you assume the risk of personal injury and damage to the E-Bike.

**To reduce this risk, read the "Safety" section, starting on page 9, before riding your E-Bike for the first time.**

This manual cannot possibly describe every conceivable hazardous situation that may arise while riding an E-Bike. The person riding the E-Bike is therefore solely responsible for the use of their E-Bike and any injuries or damage that result from such use.

---

## NOTICE FOR PARENTS AND LEGAL GUARDIANS OF MINORS

---

**The use of E-Bikes by persons under the age of 16 is strictly forbidden.**

Parents and guardians of minors are fully responsible for making sure that the minor has read and understood all of the contents of all manuals for the E-Bike.





Parents and guardians of minors are furthermore fully responsible for the results and consequences of any use, misuse, accidents, injuries or damages caused by minors.

---

# SAFETY INFORMATION

---

This manual uses the following signal words to alert to potential hazards. The meaning of the signal words is listed in the table below.

 <b>WARNING</b>	Indicates a hazardous situation that, if not avoided, could result in death or serious injury.
 <b>CAUTION</b>	Indicates a hazardous situation that, if not avoided, could result in minor or moderate injury.
<b>NOTICE</b>	Indicates information considered important, but not hazard-related (e.g. messages related to property damage).
	The symbol  is used to provide other useful information or clarifications.

---

# CONTENT

---

<b>1.</b>	<b>WHAT IS AN E-BIKE?</b>	<b>8</b>
1.1.	E-Bike drive system	8
1.2.	Brakes	8
<b>2.</b>	<b>SAFETY</b>	<b>9</b>
2.1.	Safety Gear	9
2.2.	Who is authorized to use the E-Bike?	9
2.3.	Safe riding and accident prevention	10
2.4.	Safe off-road riding	10
2.5.	Legal requirements	10
2.6.	Intended use	11
	2.6.1. Maximum gross weight and permissible loads	12
	2.6.2. Weight specifications	13
2.7.	Lifespan of your E-Bike and its components	14
<b>3.</b>	<b>ADJUSTING YOUR E-BIKE</b>	<b>15</b>
3.1.	Frame size selection	15
3.2.	Seat position	15
3.3.	Handlebar position	17
3.4.	Brake levers	16
3.5.	Suspension	18
<b>4.</b>	<b>BEFORE THE FIRST RIDE</b>	<b>19</b>
4.1.	Delivery and handover of your E-Bike	19
4.2.	Getting familiar with your E-Bike	19
<b>5.</b>	<b>SAFETY CHECK BEFORE EVERY RIDE</b>	<b>20</b>
5.1.	Quick release levers	20
5.2.	Saddle and seat post	21
5.3.	Handlebar and stem	22
5.4.	Transporting items with your E-Bike	23
5.5.	Wheels	24
5.6.	Brakes	25
5.7.	Bosch battery	27
5.8.	Lighting and reflectors	28
<b>6.</b>	<b>CHILDREN</b>	<b>29</b>
6.1.	Transporting children	29
6.2.	Children riding E-Bikes by themselves	29

---

---

<b>7.</b>	<b>OPERATION</b>	<b>30</b>
7.1.	During every ride	30
7.2.	Shifting system	30
7.3.	Brakes	31
7.4.	Adjustable stem	32
	7.4.1. Angle adjustment	33
	7.4.2. Height adjustment	34
7.5.	Racks	35
7.6.	Lighting	35
7.7.	Suspension	36
7.8.	Integrated lock	39
<b>8.</b>	<b>MAINTENANCE AND REPAIRS</b>	<b>40</b>
8.1.	Regular maintenance	40
8.2.	Initial inspection	40
8.3.	Maintenance you can do by yourself	41
	8.3.1. Cleaning your E-Bike	41
	8.3.2. Brake Inspection	42
	8.3.2.1. Test of setting of the brake levers	42
	8.3.2.2. Brake hoses	42
	8.3.2.3. Brake rotor	42
	8.3.2.4. Brake pads	43
	8.3.3. Headset	43
	8.3.4. Chain	44
	8.3.5. Belt drive	44
	8.3.6. Tires	44
	8.3.7. Wheels	45
	8.3.8. Suspension	46
	8.3.9. Lighting	46
8.4.	Maintenance that must be carried out by your authorized dealer	47
	8.4.1. Changing and replacing components	47
	8.4.2. Service and maintenance schedule	48
	8.4.3. Torque Settings	50
	8.4.4. Torque Settings for E-Cargo Bikes	51
	8.4.5. Torque Settings for adjustable Stems	51
<b>9.</b>	<b>WARRANTY TERMS AND CONDITIONS</b>	<b>52</b>
<b>10.</b>	<b>INFORMATION REGARDING PARTS THAT ARE SUBJECT TO WEAR AND TEAR</b>	<b>56</b>
<b>11.</b>	<b>E-BIKE PASSPORT</b>	<b>58</b>
	11.1. E-Bike Data	58
	11.2. Delivery Record	59
	11.3. Service Record	60





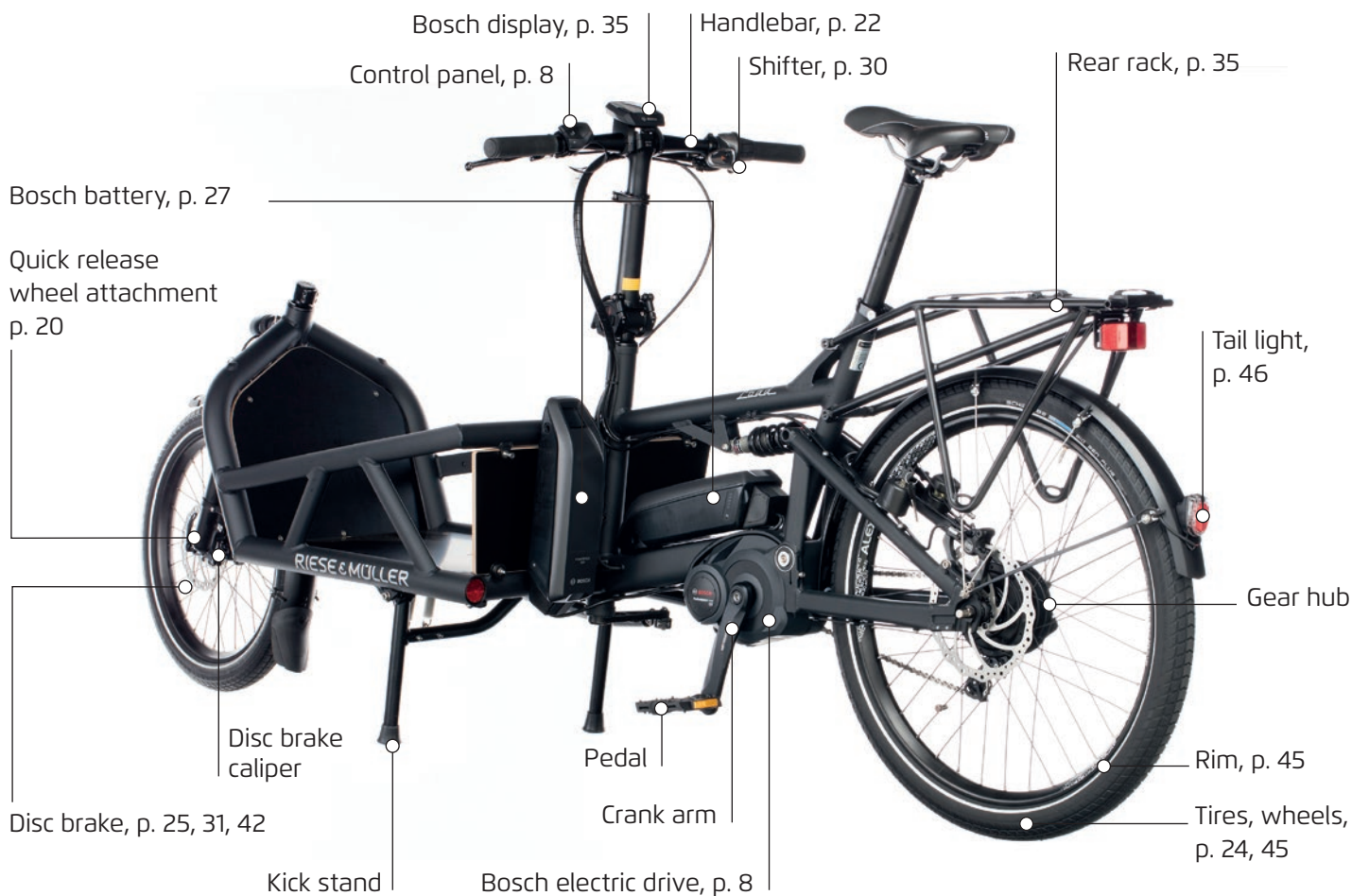
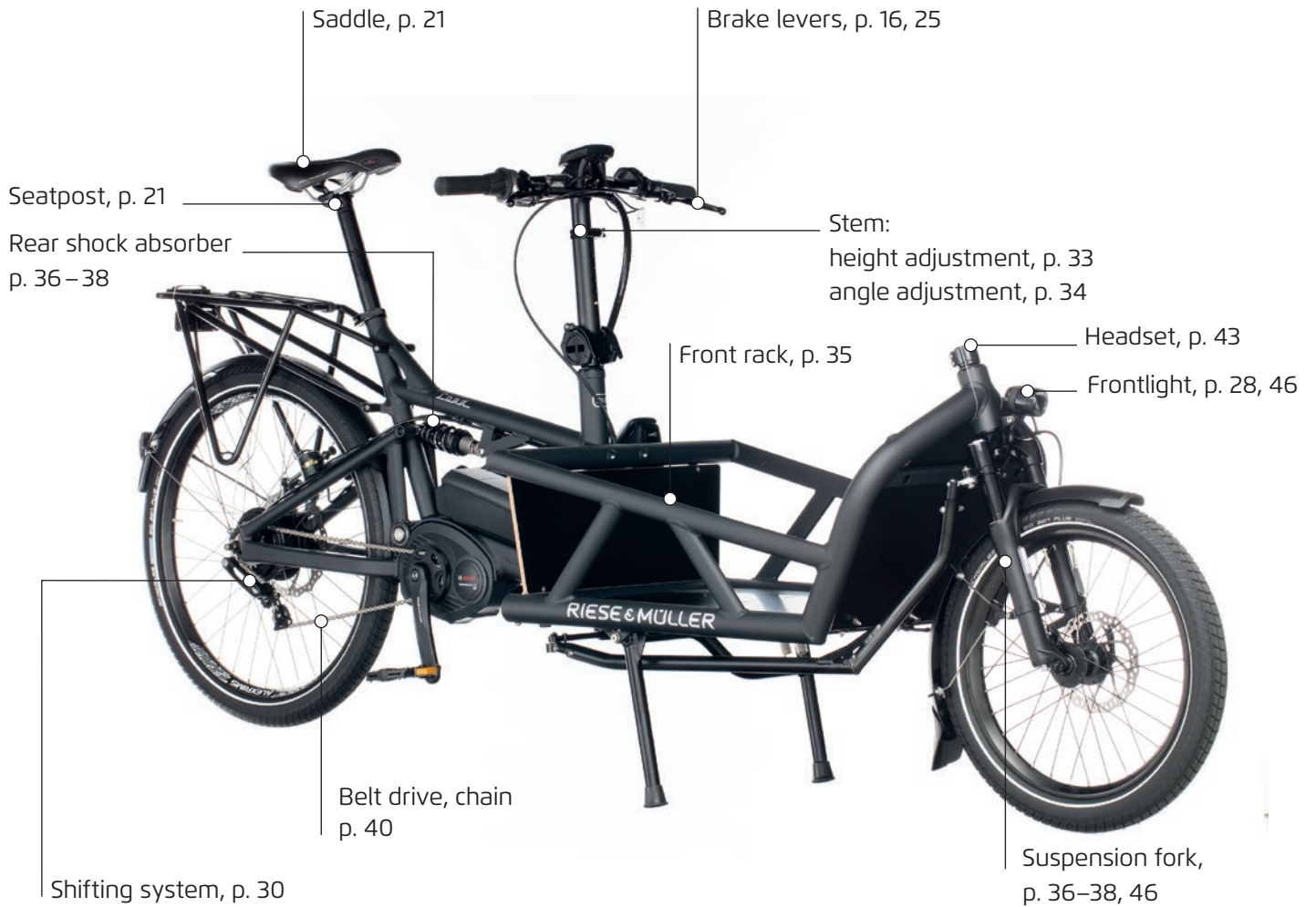

---

# 1. WHAT IS AN E-BIKE?

---

An E-Bike is a bicycle with an electric drive system that gives the rider assistance.

## 1.1. E-BIKE DRIVE SYSTEM

### **NOTICE**

***Make sure you use your Bosch drive and batteries correctly and don't cause damage.***

***Read the separate Bosch manual supplied with your E-Bike to get familiar with all details of the Bosch drive.***

All Riese & Müller E-Bikes are equipped with a Bosch drive system. The drive system consists of an electric drive, a battery and a control panel at the handlebar.

The electric drive powers the rear wheel either with a chain or with a belt drive (dependent on the particular E-Bike model).

The drive system automatically assists you, when you start to pedal. The assistance ends when you stop to pedal or when you are going faster than the maximum allowed system speed (20 mph or 28 mph).

You can adjust the assistance level via the control panel at the handlebar. You can also turn the assistance off and ride the E-Bike like a regular bicycle.

The battery must be charged separately using the supplied charger. You cannot charge the battery by pedaling. Some E-Bikes are equipped with an optional second battery.

## 1.2. BRAKES

Dependent on which E-Bike model you have, your E-Bike is equipped either with disc brakes or rim brakes. The E-Bikes shown as examples on the inner sides of the cover of this manual are equipped and shown with disc brakes.

---

## 2. SAFETY

---

### **WARNING**

*Always wear protective clothing, safety gear and a well-fitting helmet to protect against severe injuries in case of an accident.*

*Observe and follow all instructions of the helmet manufacturer.*

*Prior to every ride, perform a safety check.*

*Use your E-Bike only as intended.*

*Never ride under the influence of alcohol, drugs or prescription medication.*

*Off-road riding is more hazardous and requires greater skills. Make sure to avoid serious injuries by practicing on easy terrain first.*

*Be sure to be seen by other drivers and other traffic when riding at night or when visibility is bad. Do not ride unless your lighting system is switched on and fully operational.*

*After a fall or an accident, have the E-Bike inspected and, if necessary, repaired by an authorized dealer to ensure safety and prevent further accidents.*

### **2.1. SAFETY GEAR**

Wear protective clothing when riding your E-Bike. Such clothing must provide good visibility and reflect light. Do not wear loose-fitting clothes to avoid entanglement with your E-Bike or covering the lighting system or reflectors.

Protective gear is available for each part of your body. Always wear biking gloves, sturdy shoes and protective goggles. Riding without protective clothing and other protective gear increases the risk of serious injury.

### **2.2. WHO IS AUTHORIZED TO USE THE E-BIKE?**

The minimum age for anybody to ride an E-Bike is 16 years.

All riders must be healthy enough as well as both physically and mentally fit to control an E-Bike. They must be able to negotiate traffic in a safe manner and in compliance with all applicable laws and regulations.

---

## 2. SAFETY

---

### 2.3. SAFE RIDING AND ACCIDENT PREVENTION

1. Before to every ride, perform the safety check described in the section 5 on page 18, "Safety check before every ride".
2. Adjust your riding style and speed to the weather and the conditions of the road.
3. Do not overestimate your abilities.
4. Avoid riding on slippery ground and when visibility is poor. Heightened attention is required in the rain and on wet or loose ground like sand, gravel, etc. because of the increased risk of slipping in curves or falling when applying the brakes.
5. Always follow all traffic rules applicable in your city and state.
6. Never ride while under the influence of alcohol, drugs or prescription medication.
7. Be careful as plastic and rubber pedals often become very slippery when wet! Your foot may slip off, causing severe injury.
8. If the pedals on your E-Bike are fitted with rubber or plastic toe cages, make yourself familiar with the grip they provide.

### 2.4. SAFE OFF-ROAD RIDING

Riding your E-Bike off-road poses greater hazards and therefore requires greater skills and some practice on easy terrain.

Start by riding on easy terrain and become accustomed to the way your E-Bike handles off-road.

Keep in mind that the conditions of the ground may change at any time while riding off-road. Pay attention to animals and other people. Never ride all alone in remote areas.

### 2.5. LEGAL REQUIREMENTS

Make yourself familiar with the local and regional laws and regulations applicable for the use of E-Bikes.

Be aware that different rules may be in place for fast E-Bikes (maximum assisted speed = 28 mph) as opposed to slow E-Bikes (maximum assisted speed = 20 mph).

Different states may have different laws and regulations regarding the wearing of helmets, having a driver's license or speed limits of your E-Bike like. Even if not required by law, always wear a well-fitting helmet.

Be aware that you may not be allowed to ride your E-Bike in all places.

It is the rider's sole responsibility to be familiar with and comply with all applicable laws and regulations.

---

---

## 2.6. INTENDED USE

### **WARNING**

***No E-Bike is suitable for all potential applications or purposes.***

***Choose the E-Bike that matches your intended application best.***

***Using your E-Bike for an unintended purpose is hazardous.***

E-Bikes from Riese & Müller are intended and suited for a wide range of applications. The following is a description of this range of applications.

The Riese & Müller E-Bikes “Charger mountain” and “Delite mountain” are designed for category 2. All other Riese & Müller E-Bikes are designed for category 1.

#### **Category 1: Day-to-day use**

Category 1 E-Bikes are suited for: Riding on bike lanes, paved streets and roadways. The front and rear wheels maintain constant contact with the ground.

Not suited for: Riding off-road, riding over stairs, jumps, wheelies, competitions.

#### **Category 2: Off-road use**

Category 2 E-Bikes are suited for: All applications of category 1 plus moderate off-road riding. Skilled riders can master unpaved roadways and minor jumps off a maximum height of 12 inches (1 foot).

Not suited for: heavy-duty off-road operation, downhill, slope style and freeride biking, competitions, tricks and stunts.

---

## 2. SAFETY

---

### 2.6.1 Maximum gross weight and permissible loads

#### **WARNING**

***Avoid accidents, serious injuries and damage to your E-Bike.***

***Never overload your E-Bike.***

***Never exceed the permissible gross weight of your E-Bike.***

Your E-Bike has a maximum permissible gross weight. The maximum permissible gross weight must never be exceeded. If you do not stay below the maximum permissible gross weight limit you are using your E-Bike in an improper and impermissible fashion that can lead to accidents, injuries and severe damage to your E-Bike.

The maximum gross weight is the sum of your E-Bike's weight plus the weight of the trailer, the biker and the load you put on the racks.

The manufacturer assumes no liability and your warranty will be voided if you fail to use your E-Bike as intended, if you do not adhere to the safety instructions or if you fail to have any defects repaired properly. Furthermore, the manufacturer assumes no liability for and declines to provide any warranty in case of installation errors, willful misuse, accidents and failure to observe the instructions on maintenance and care.

The table 2.6.2. on page 13 shows the maximum permissible weight limits of the different models of Riese & Mueller E-Bikes.

## 2.6.2. Weight specifications

E-BIKE MODEL	MAXIMUM GROSS WEIGHT	WEIGHT OF E-BIKE	MAX. WEIGHT OF RIDER	MAX. LOAD ON REAR RACK	MAX. LOAD ON FRONT RACK
Avenue	140 kg 308 lbs	26.6 – 27.3 kg 59 – 60 lbs	110 kg 242 lbs	20 kg 44 lbs	--
Culture	140 kg 308 lbs	26.7 – 27.5 kg 59 – 61 lbs	110 kg 242 lbs	20 kg 44 lbs	--
Delite	140 kg 308 lbs	23.0 – 28.0 kg 51 – 62 lbs	110 kg 242 lbs	20 kg 44 lbs	--
Delite mountain	140 kg 308 lbs	23.0 – 26.0 kg 51 – 58 lbs	110 kg 242 lbs	20 kg 44 lbs	--
Homage	140 kg 308 lbs	25.7 – 26.8 kg 57 – 59 lbs	110 kg 242 lbs	20 kg 44 lbs	--
Kendu	140 kg 308 lbs	25.9 kg 57 lbs	100 kg 220 lbs	20 kg 44 lbs	--
Load	190 kg 418 lbs	32.6 – 35.1 kg 72 – 78 lbs	110 kg 242 lbs	20 kg 44 lbs	100 kg 220 lbs
Packster	200 kg 441 lbs	34.9 – 52.9 kg 77 – 117 lbs	110 kg 242 lbs	20 kg 44 lbs	100 kg 220 lbs
Charger	140 kg 308 lbs	19.9 – 26.6 kg 44 – 59 lbs	110 kg 242 lbs	17 kg 37 lbs	3 kg 6 lbs
Charger mountain	140 kg 308 lbs	19.9 – 23.0 kg 44 – 51 lbs	110 kg 242 lbs	17 kg 37 lbs	--
Charger GH	160 kg 353 lbs	27.2 kg 60 lbs	135 kg 297 lbs	17 kg 37 lbs	--
Cruiser	140 kg 308 lbs	24.8 – 25.8 kg 55 – 57 lbs	110 kg 242 lbs	30 kg 66 lbs	3 kg 6 lbs
Nevo	140 kg 308 lbs	24.3 – 26.2 kg 54 – 58 lbs	110 kg 242 lbs	17 kg 37 lbs	--
Roadster	140 kg 308 lbs	21.9 – 22.5 kg 48 – 50 lbs	110 kg 242 lbs	20 kg 44 lbs	--
Swing	130 kg 286 lbs	24.9 – 26.1 kg 59 – 60 lbs	100 kg 220 lbs	25 kg 55 lbs	3 kg 6 lbs
Tinker	135 kg 297 lbs	21.9 – 23.8 kg 48 – 52 lbs	110 kg 242 lbs	20 kg 44 lbs	--

---

## 2. SAFETY

---

### 2.7. LIFESPAN OF YOUR E-BIKE AND ITS COMPONENTS

#### **WARNING**

*E-Bikes are subject to wear and tear.*

*Bring your E-Bike to your authorized dealer for regular inspections and timely replacement of safety relevant components like handlebar, stem or suspension fork.*

*After reaching the end of their product lifetime, the components of your E-Bike may fail abruptly and cause falls and serious injuries.*

If subjected to moderate use, the E-Bikes from Riese & Müller have a product lifetime of 10 years or 20,000 miles. The wear and tear of an E-Bike, however, largely depends on the load, the road conditions and the riding style.

When exposing your E-Bike to a lot of stress (e.g. total vehicle load of 242 lbs or more, riding over unpaved roadways or curbstones, riding in dirty and corrosive environments) on a regular basis, you may experience that the lifetime of your E-Bike shortens to about 10,000 miles.

**When your E-Bike has reached the end of its product lifetime, it is no longer roadworthy and safe.**

Please note that components such as the handlebar, stem, and suspension fork or rear shock absorber have a significantly shorter product lifetime. Actual product lifetimes of these components are also subject to the above mentioned conditions. Please consult your authorized dealer who can determine whether and when a component has to be replaced.



---

## 3. ADJUSTING YOUR E-BIKE

---

Before you can go on your first ride, your authorized dealer must adjust your new E-Bike to your height, proportions and individual requirements.

### 3.1. FRAME SIZE SELECTION

Your authorized dealer shall select the frame size that is appropriate for you. Make sure that the standover clearance of your E-Bike fits your body and proportions. A minimum standover clearance of 2" to 5" is recommended.

- Place the E-Bike between your legs.
- Measure the distance indicated by the arrow.
- This is the standover clearance.



*Standover clearance*

### 3.2. SEAT POSITION

Your authorized dealer shall explain and set the seat position that fits you best. When adjusting the height of the saddle yourself, proceed as follows:

- Rotate one pedal to its bottommost position
- Sit down on the saddle and place your heel on this pedal. Your leg must now be fully extended.
- If the leg is not fully extended, the saddle is too low.
- If the heel does not reach the pedal, the saddle is too high.



*Heel on the lower pedal*

### 3. ADJUSTING YOUR E-BIKE

- Sit down on the saddle.
- Make sure that the tips of both of your feet reach the ground.
- If the tips do not reach the ground or if you feel unsafe, the saddle is too high.



*Feet with tips on the ground*

- Check the seat post height.

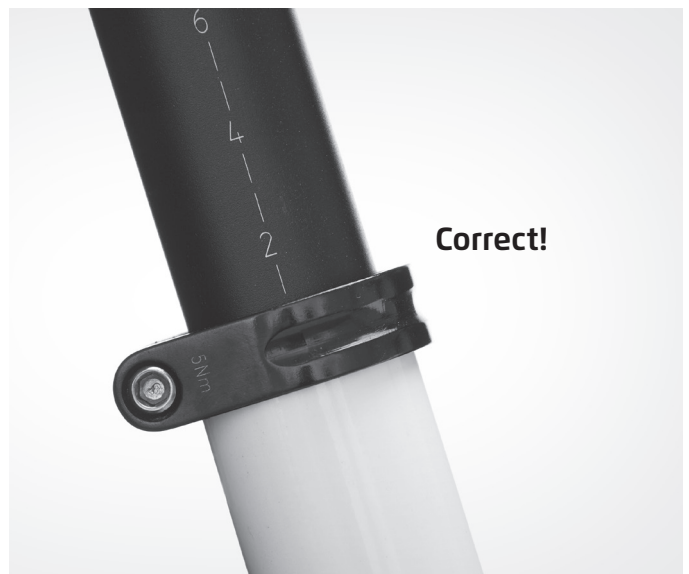

**Correct:** Hidden minimum insertion mark of the seat post

- The seat post must not be extended too far. Make sure that the line that indicates the minimum insertion is not visible.

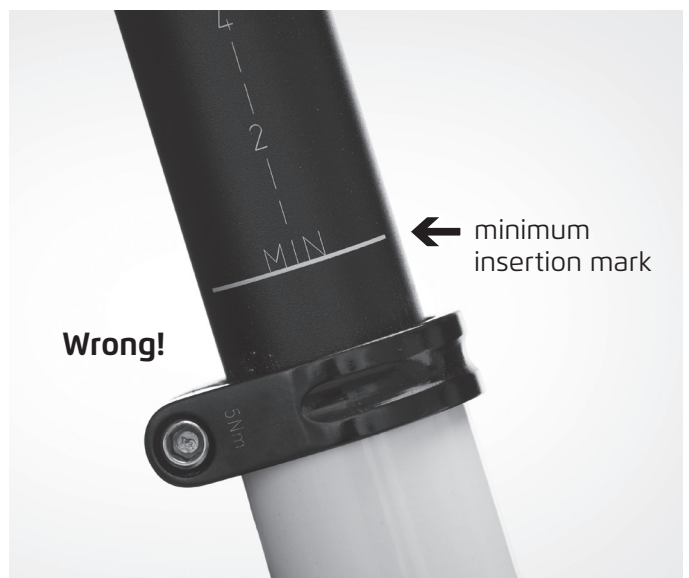

**Wrong:** Visible minimum insertion mark of the seat post

---

---

### 3.3. HANDLEBAR POSITION

Your authorized dealer shall explain and set the appropriate position of handlebar, grips and all control elements such as brake and shift levers and the Bosch display.

On E-Bikes with an adjustable stem, the authorized dealer must adjust the stem to the position that fits you best and explain how to use the adjusting mechanism.

### 3.4. BRAKE LEVERS

Check and make sure that you can operate the front brake with the same brake lever (right of left) in the way that is familiar to you. If you are used to having the front brake operated with the lever on the other side, ask your authorized dealer to mount the brake cables in the appropriate fashion so you can operate the front brake with the hand you are used to and, of course, the rear brake with the other hand, as you are used to.

The factory set-up is that the left brake lever is operating the front brake (as shown below).



*Factory set-up*



*Modified set-up (brake cables switched), if so desired*

---

## 3. ADJUSTING YOUR E-BIKE

---

### 3.5. SUSPENSION

 **WARNING**

*A suspension setting that is too soft leads to more compression of the suspension and less distance between the pedals and the ground.*

*Make sure that the suspension is set accurately for the rider's weight.*

*Suspension settings that are too soft may result in unexpected and hazardous ground contact of your pedals and lead to a crash and injuries.*

*Suspension settings that are too hard may result in loss of traction and lead to a crash and injuries.*

Your authorized dealer shall explain and set the suspension. Review and follow the instructions in the included manuals from the suspension manufacturer.

---

## 4. BEFORE THE FIRST RIDE

---

### 4.1. DELIVERY AND HANDOVER OF YOUR E-BIKE

Your authorized dealer shall get your E-Bike ready to ride and for safe operation. The authorized dealer shall, furthermore, perform a final check and a test ride with your E-Bike. The delivery and handover of your E-Bike must be documented in the E-Bike's delivery record (see section 11.5. on page 55).

### 4.2. GETTING FAMILIAR WITH YOUR E-BIKE

#### **WARNING**

*Avoid injuries to yourself and others.*

*Using your E-Bike in an inappropriate manner may lead to loss of control and hazardous situations.*

*Read all instructions and get familiar with all components of your E-Bike before you ride on public roads or in traffic.*

Read all instructions and manuals of this E-Bike carefully and make sure you understand everything.

Pick a location with little traffic to make yourself familiar with the functions and operation of your new E-Bike. Pay particular attention to the operation of the brakes, shifters and the electric drive system.

Read all instructions for the correct use of quick-releases and make sure you fully understand them.

Read all instructions and safety messages that are attached to the quick release levers at the front and rear wheels.

In addition, read and understand chapter 5.1. on page 18.

If you experience problems with the operation of your E-Bike, contact your authorized dealer.

---

## 5. SAFETY CHECK BEFORE EVERY RIDE

---

The following is a list of important checks that you must perform before every ride.

### 5.1. QUICK RELEASE LEVERS

#### **WARNING**

*Avoid crashes and injuries.*

*Improper use of a quick release lever for a wheel may cause the wheel to fall off during the ride.*

*Improper use of other quick release levers may cause the saddle or handlebar stem to become loose.*

*Quick release levers can be opened easily. Be sure to carefully read and understand the instructions attached to the quick release levers or delivered separately with your E-Bike.*

*If you have any questions ask your authorized dealer.*

*It is very important for your safety that you check all quick releases of your E-Bike even if you parked it unattended for only a short time only. You have to be sure that all quick releases are properly closed before you start riding your E-Bike.*

1. Close all existing quick release levers at wheels, seat post and stem. Make sure that the levers do not protrude.
2. Closing the lever needs only a little force in the beginning and a lot of force when the lever is nearly closed.



3. If it is too hard to fully close the lever, open the lever again and loosen the adjustment nut at the opposite side a little bit by turning it counter clockwise.
4. If the quick release lever can easily be pushed to the closed position, this means the clamping force is insufficient.

Open the lever again and tighten the adjustment nut at the opposite side a little bit by turning it clockwise.

5. **⚠ WARNING** *Never try to fasten a wheel by rotating the quick release lever as shown on the right. Detachment of the wheel as a result of improper use of quick release can result in serious injury. Always use the adjustment nut on the other side.*

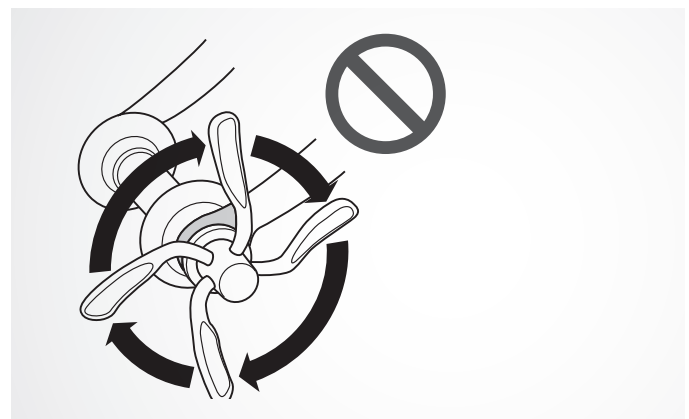
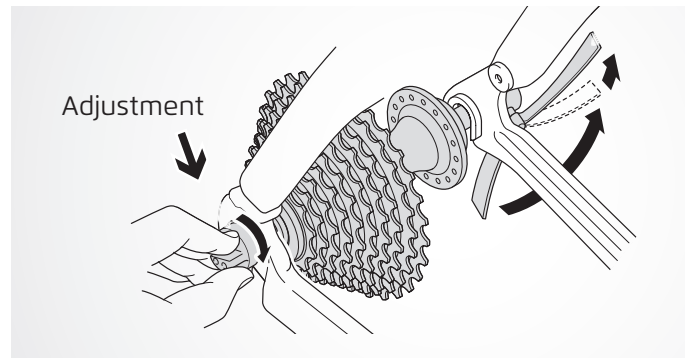

(Source: Shimano techdocs)

## 5.2. SADDLE AND SEAT POST

Check whether the saddle and seat post are properly secured. Try to twist or move the saddle. The saddle or seat post must not move. If your E-Bike is equipped with a seat post clamp with quick release, you have to check whether the saddle is set to the correct height (see section 3.2. on page 15).

## 5. SAFETY CHECK BEFORE EVERY RIDE

### 5.3. HANDLEBAR AND STEM

1. Make sure the handlebar is at a right angle relative to the front wheel.
2. Place the front wheel between your legs and try to twist the handlebar. If you can twist the handlebar, you must tighten the quick release of the height adjustment. If no quick release exists, you must immediately contact your authorized dealer to check the bolts.
3. Try to twist the handlebar toward the stem to make sure it does not rotate. If you can twist the handlebar, you must immediately contact your authorized dealer to check the bolts.
4. Check whether the grips as well as the brake and shift levers are properly secured. It must not be possible to twist them relative to the handlebar.
5. Check whether the handlebar can be turned in both directions without resistance and without jamming or pinching any of the hoses or cables.
6. If your bike comes with an adjustable stem, check whether all pins are engaged and all quick release levers are properly closed (see section 7.4. on page 32).

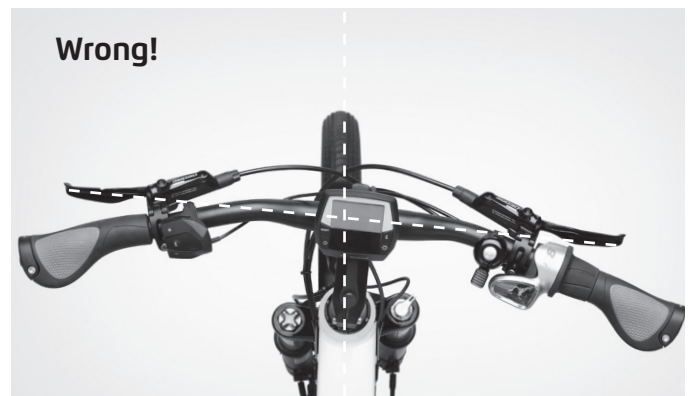

*Adjustable stem*



---

---

## 5.4. TRANSPORTING ITEMS WITH YOUR E-BIKE

### **WARNING**

*Overload can lead to loss of control, hazardous situations or severe injuries.*

*The E-Bike may handle differently when loaded, especially with heavy loads.*

*The braking distance of a loaded E-Bike may increase significantly.*

*Never exceed the maximum permissible load of the E-Bike.*

Make sure you never exceed the maximum permissible load (see section 2.7.1. on page 12).

Always secure all loads properly so that there are no loose fasteners that can become entangled in the wheels or other moving parts of the E-Bike.

## 5. SAFETY CHECK BEFORE EVERY RIDE

### 5.5. WHEELS

#### WARNING

*Verify before every ride that the wheels are securely fastened*

*If not fastened securely, one or both wheels can fall off and can cause a crash, accident or severe injuries.*

1. Check the air pressure of your tires. The air pressure that must be maintained is indicated on the side of the tire. Do not overinflate or underinflate your tires.



2. Check the wheels for smooth and free turning. Turn both wheels and focus on the rim and the tire. Make sure the rim does not rub against the rim brake pads and is not damaged or deformed. Make sure the tire does not rub against any other parts.

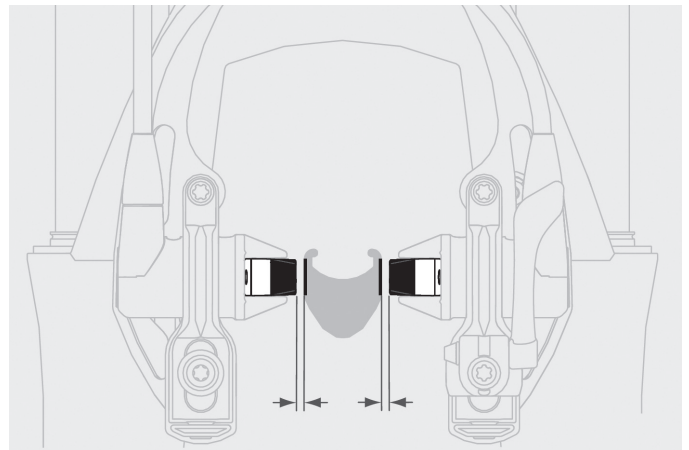

*Rim brake pads do not rub at rim*

3. Lift the E-Bike so that one wheel is off the ground. Hit the top of the tire a few times. Make sure the wheel is not loose or comes off.

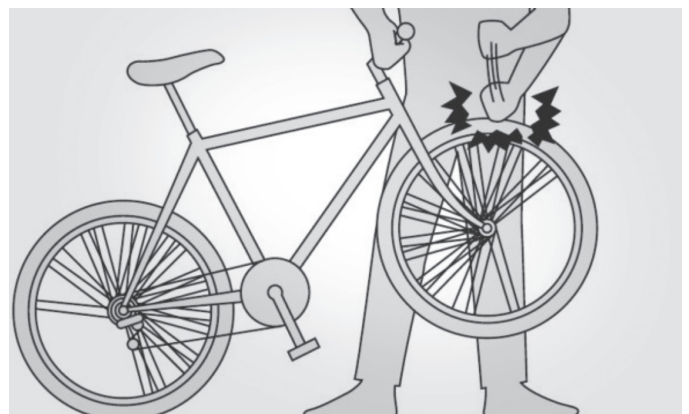

*(Source: Shimano techdocs)*

4. Repeat these steps on the other wheel.

## 5.6. BRAKES

### **WARNING**

*Avoid accidents and serious injuries caused by faulty brakes.*

*Keep the brakes clean and in good working order.*

*If there is a problem with the brakes, do not ride your E-Bike and take it to your authorized dealer for inspection and repair*

To check proper functioning of the brakes, pull both brake levers. Make sure you feel a distinct pressure point and that you cannot pull the levers all the way to the grip.

 *Your hand is hidden in both illustrations for better visibility of the brake levers.*

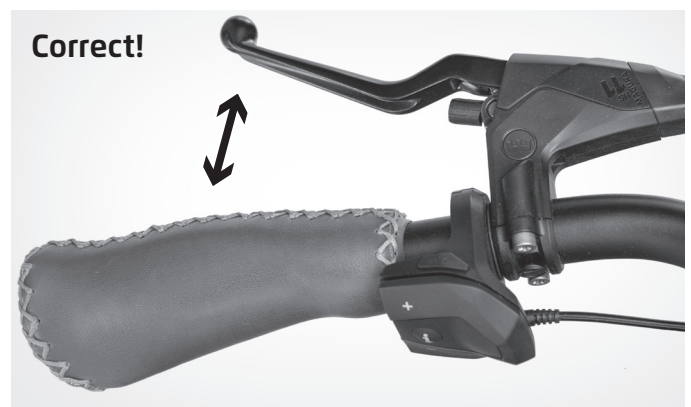

**Correct:** Lever does not touch grip

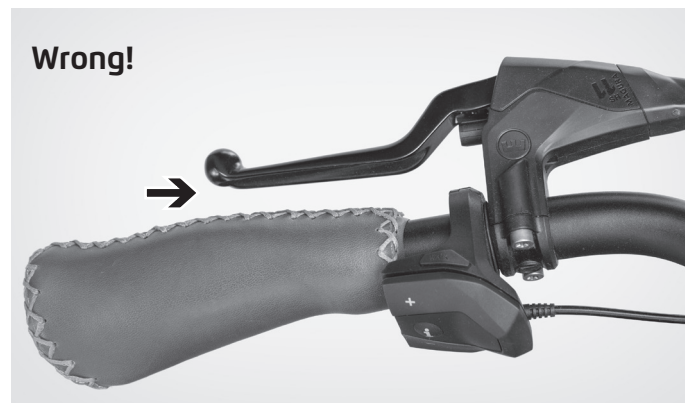

**Incorrect:** Lever too close to the grip

## 5. SAFETY CHECK BEFORE EVERY RIDE

If your E-Bike is equipped with rim brakes, the rim brakes must not touch the tire (see arrow). Check that the brake pads and the rims or brake discs are in good working order and not worn out. For details refer to section 8.3.2. on page 38.

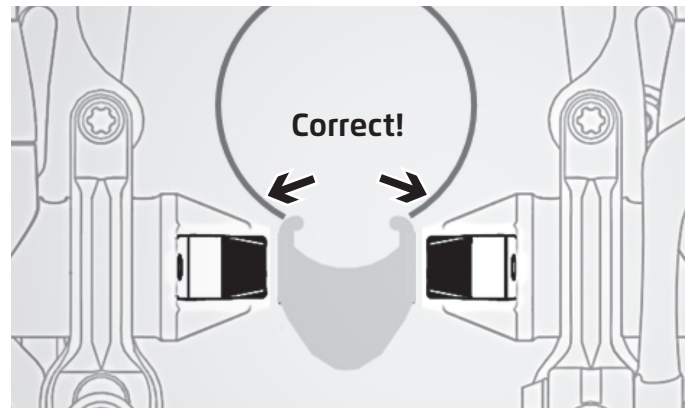

**Correct:** Rim brake pads do not touch tire

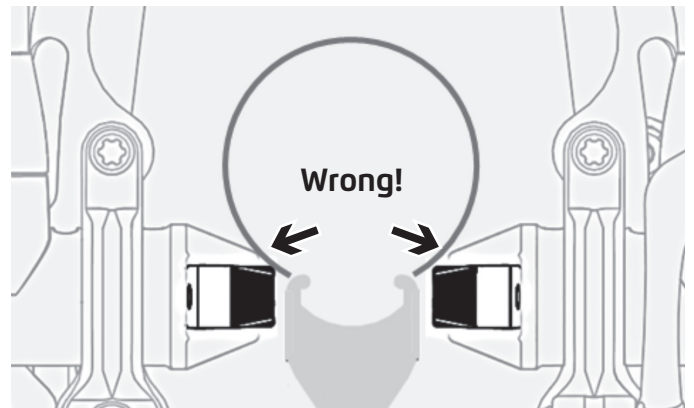

**Incorrect:** Rim brake pads touch tire

---

---

## 5.7. BOSCH BATTERY

### NOTICE

***An E-Bike battery is heavy. It may fall down and become damaged.***

***Be sure not to drop the battery and to always secure it in its bracket.***

Read the separate manual for the Bosch drive system to get familiar with the battery. In the Bosch manual the battery is referred to as "battery pack".

Every time you insert a battery, make sure it is seated firmly by pressing it into its bracket until it locks in place with an audible click.



*Press battery into locked position*

Remove the key from the lock and briefly try to pull the battery out to ensure that it is properly and securely locked in the bracket.



*Try to pull battery*

---

## 5. SAFETY CHECK BEFORE EVERY RIDE

---

### 5.8. LIGHTING AND REFLECTORS

Check whether the headlight and tail light work properly and whether the headlight has been adjusted correctly.

Correct adjustment is shown in this illustration.

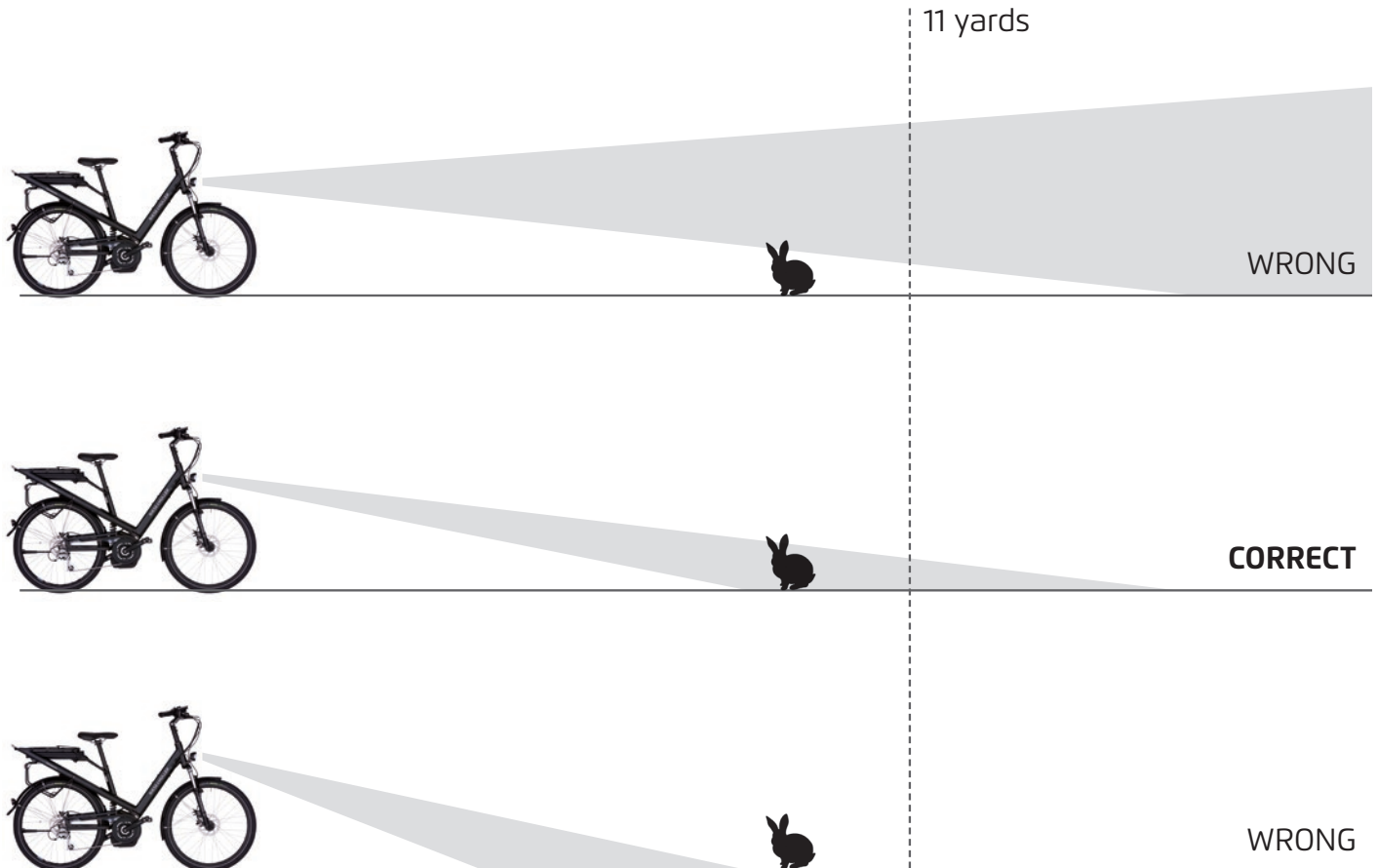

Consult your authorized dealer if you have any questions regarding the correct setting of the range of the headlight.

Make sure that all reflectors are present and uncovered.

---

## 6. CHILDREN

---

### **WARNING**

*When transporting a child, your E-Bike will handle differently. The braking distance will increase as well.*

*Practice riding with a child in a safe location without traffic. Practice and familiarize yourself with the handling of the E-Bike until you feel safe and comfortable riding with a child.*

### **6.1. TRANSPORTING CHILDREN**

Make sure before every time you transport a child that:

- You use only a child seat or trailer that is tested and certified by the respective manufacturer for use in combination with an E-Bike.
- Any child seat or trailer you use is securely attached to your E-Bike. If you have any questions, consult your authorized dealer.
- The child is strapped in securely with safety belts.
- The child is wearing a helmet at all times.
- You do not exceed the maximum permissible gross weight of your E-Bike.
- You do not exceed the maximum permissible gross weight of the trailer.
- Saddle springs must be covered so that children cannot stick in their fingers.
- It is impossible for any part of the child's body to become entangled in the spokes or any other moving parts of the E-Bike.
- You take your child out of the child seat when the E-Bike is parked.
- You never leave a child unattended when seated in the child seat or trailer.

### **6.2. CHILDREN RIDING E-BIKES BY THEMSELVES**

Parents and guardians are responsible for their children. Make sure that all of the following requirements have been met before your child is riding your E-Bike or any other E-Bike.

- The child is at least 16 years of age.
- Your authorized dealer has properly adjusted the E-Bike to the height and proportions of your child.
- The standover clearance (see section 3.1. on page 14) of the E-Bike fits to your child.
- The E-Bike used by your child is regularly maintained and kept in good and safe working condition at all times.
- You have instructed your child on the applicable traffic rules and on how to act responsibly in traffic.
- You have read this manual together with your child and explained its contents.
- Your child is wearing a helmet when riding an E-Bike.
- The helmet fits your child properly.
- The helmet is replaced after each fall.

**Never allow your child to ride off-road unless accompanied by an adult.**

# 7. OPERATION

The following is a list of important checks that you must perform before every ride.

## 7.1. DURING EVERY RIDE

You must observe the following during every ride to maintain your safety:

- Always hold the handlebar firmly with both hands to keep control of your E-Bike and to avoid hazardous situations, accidents and injuries.

**⚠ WARNING** *Riding a defective E-Bike could decrease your control and cause you to fall.*

- If your E-Bike behaves in an unusual manner or you hear an unusual noise, immediately stop the E-Bike and identify the problem. Make sure any problem is rectified before you ride again.
- Bring your E-Bike to your authorized dealer after any impact for a thorough inspection or any necessary repair, adjustment or service.

## 7.2. SHIFTING SYSTEM

Select gears that best allow you to pedal at a speed that feels comfortable to you regardless of the incline. When shifting gears it is important for you to keep pedaling steadily and without excessive force until you reach the next gear. Refrain from switching gears while pressing the pedals with great force.

Dependent on the particular model, E-Bikes from Riese & Müller use two kinds of shifters:

**Twist grip:** Rotating the right grip towards the driver leads to an easier gear and rotating the left grip away from the driver leads to an easier gear. The grip indicates which gear you are currently using.

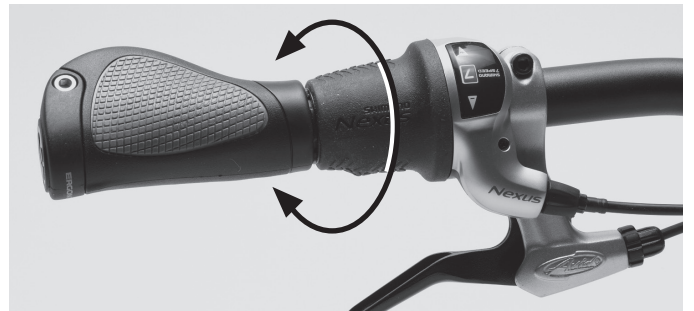

**Rapid Fire shifter:** The thumb on the right side shifts to easier gears and the index finger on the right side shifts to harder gears.

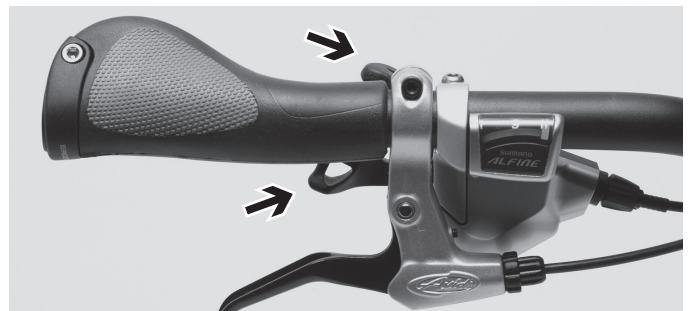

### NOTICE

***Read the included instruction manual supplied by the gearshift manufacturer or have your authorized dealer explain its operation to you.***



---

---

## 7.3. BRAKES

### **WARNING**

*Modern E-Bike brake systems like disc brakes and hydraulic rim brakes are very powerful.*

*Carefully make yourself familiar with the brakes.*

*Safely practice emergency braking in a traffic free area until you feel confident that you can control your E-Bike and its brakes in hazardous situations that could lead to accidents and severe injuries.*

*Be aware that wet or rainy conditions affect the brakes and lead to longer braking distances.*

*Do not brake forcefully on loose ground, such as sand, gravel or loose dirt to prevent the front wheel from slipping or locking.*

*Brakes will heat up during breaking. Use the brakes only intermittently on long downhill rides. Briefly release the brakes at regular intervals to allow the brakes to cool down.*

*The brakes will otherwise become very hot and may even fail.*

*Brake pads and rotors become very hot during use. A brake rotor has sharp edges.*

*Avoid injuries and never touch a brake rotor that is hot or rotating!*

You use the brakes to slow down or stop your E-Bike. The safety of any braking maneuver largely depends on your abilities. For this reason, it is important and part of the duties of your authorized dealer when you pick up your new E-Bike to carefully explain to you how to operate the brakes correctly.

The front brake can transfer a much greater braking power because of the weight shift towards the front during braking. When braking, be sure to keep the front wheel from locking. Otherwise your E-Bike may flip over or slip and you will fall. Apply both brakes at the same time, keeping the above in mind.

When braking on loose ground, such as sand, gravel or loose dirt, be very careful when applying the front brake to prevent slipping or locking of the front wheel.

---

## 7. OPERATION

---

### 7.4. ADJUSTABLE STEM

Some E-Bikes from Riese & Müller are equipped with an adjustable stem. The stem is either height-adjustable or both height- and angle-adjustable. The adjustment is made without tools, and the stem is fastened and secured with lock pins and quick release levers.

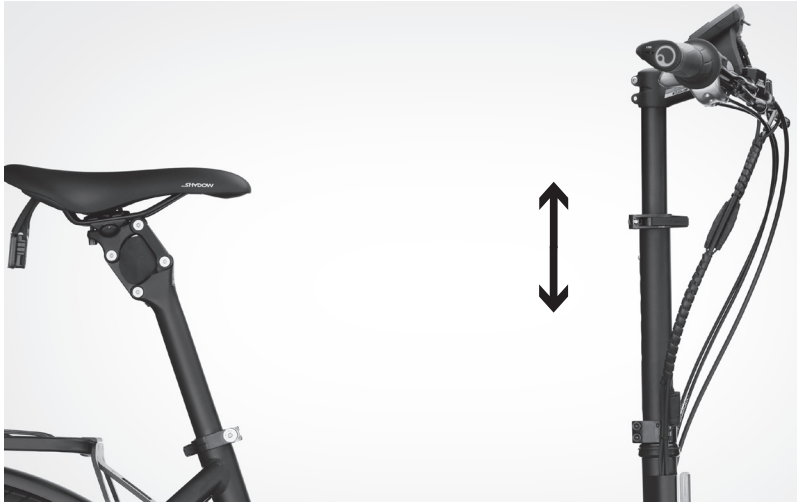

*Stem with height adjustment*



*Stem with height and angle adjustment*

## 7.4.1. Angle adjustment

### **⚠ WARNING**

*Make sure prior to every ride that the pin is engaged properly and the quick release levers are closed all the way.*

*Stop immediately if the stem shifts position by self during your ride.*

*Do not longer use your E-Bike and consult your authorized dealer immediately to have the stem inspected.*

*Failure to close the stem fixation properly may result in hazardous situations, accidents, injury or death.*

If you want to adjust the stem, proceed as follows:

1. Open both quick release levers **A** on the stem hinge.
2. Press and hold the button **B**.  
Set the stem to one of the three angle positions **C**. Release the button **B** and make sure the button engages. To check, rock the stem back and forth a little.
3. **⚠ WARNING** *Only use the three stem positions **C** that are secured by the button **B**!*  
Failure to make sure that the button **B** has properly engaged and has locked the stem in place, may result in the stem coming loose while riding and lead to hazardous situations, accidents and injuries.
4. When the stem is locked in place, the red lines on the side of the stem hinge line up on top of each other (see lines **D**).
4. Close both quick release levers **A**.

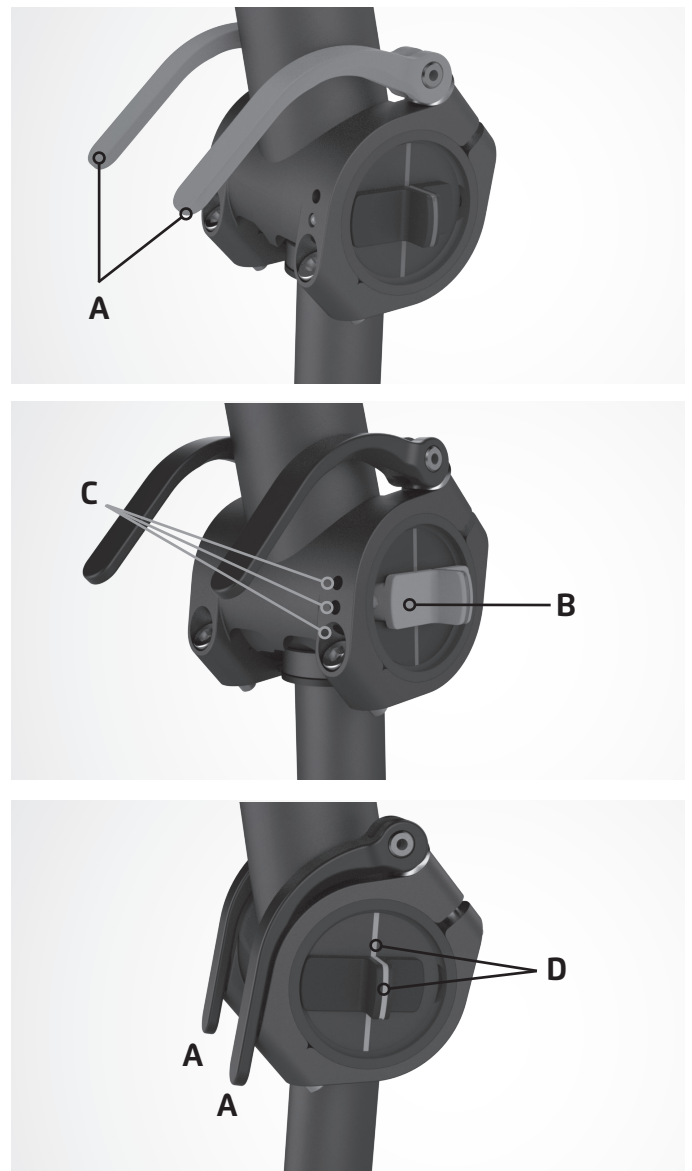

# 7. OPERATION

## 7.4.2. HEIGHT ADJUSTMENT

### **⚠ WARNING**

*Make sure that prior to every ride that the pin B is engaged properly and the quick release lever is closed all the way.*

*Stop immediately if the handlebar shifts position by itself during your ride.*

*Do not longer use your E-Bike and consult your authorized dealer immediately to have the stem inspected.*

*Failure to close the clamping at stem and/or handlebar properly may result in hazardous situations, accidents or injuries.*

1. Open the quick release lever **A**.
2. Press the lock pin **B** and adjust the height of the stem. With the lock pin **B** having been pressed, the stem can be moved to different height settings.
3. Depending on the stem type there are 5 or 6 different height settings available
4. Choose the correct height setting and make sure that the lock pin **B** engages again.
5. **⚠ WARNING** *Choose only stem height settings that are secured by the engaged lock pin B!*

*No position in between the holes are secured by the lock pin B and therefore are not safe. Failure to properly engage the lock pin B may result in hazardous situations, accidents and injuries.*

6. Close the quick release lever **A**.

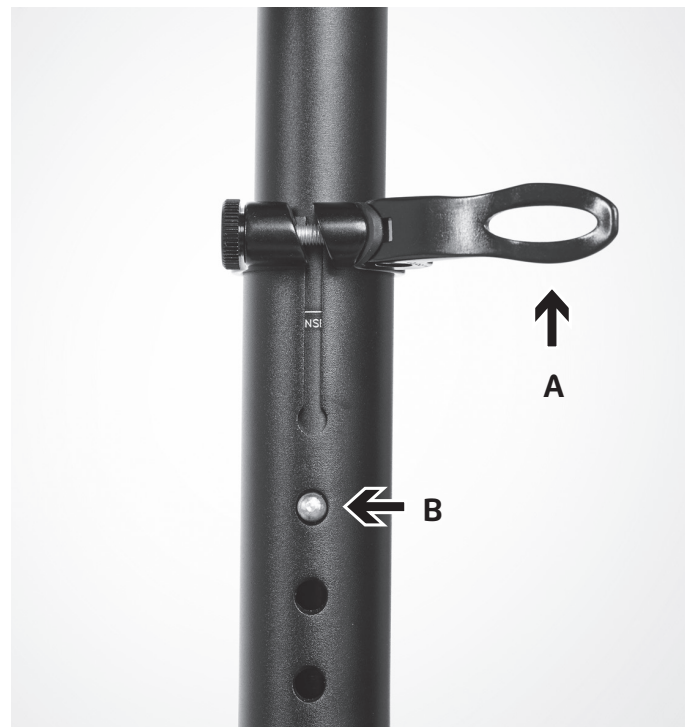

---

---

## 7.5. RACKS

Never exceed the maximum permissible loads for the rear and front racks. For details refer to table 2.6.2. on page 12.

An E-Cargo bike may be equipped with additional optional accessories. Follow the additional instructions in the included manuals for these accessories.

## 7.6. LIGHTING

The light on all E-Bikes from Riese & Müller is switched on and off on the Bosch display. Read the included Bosch manual for more information.



# 7. OPERATION

## 7.7. SUSPENSION

### **WARNING**

*A suspension setting that is too soft leads to more compression of the suspension and less distance between the pedals and the ground.*

*Make sure that the suspension is set accurately for the rider's weight.*

*Suspension settings that are too soft may result in unexpected and hazardous ground contact of your pedals leading to a crash and injuries.*

*Suspension settings that are too hard may result in loss of traction and lead to a crash and injuries.*

*Always keep the crank arms horizontal when riding through curves or passing over bumps in the road. This keeps the pedals from making contact with the ground.*

*Practice to make sure the pedals never touch the ground. Practice at slow speed and in a traffic-free area.*

*If the pedals scrape the ground, you may fall and sustain serious injuries.*



**Good:** Crank arms horizontal



**Hazardous:** Crank arms not horizontal

Your authorized dealer shall explain and set the suspension. Review and follow the instructions in the included manuals from the suspension manufacturer.

**i** Adjustment of the suspension is recommended to be done by your authorized dealer who has the expertise and special tools necessary to properly adjust the suspension settings.

Don't try it yourself unless you have all the tools and fully understand what to do. In any case, if in doubt, contact your authorized dealer. For more details on how to adjust the suspension, please refer to the separately included instruction manual supplied by the suspension manufacturer.

The hardness of the air suspension can be adjusted with the included suspension pump. It changes the air pressure in the suspension of the front fork or the rear shock absorber.



Suspension pump at the front fork



Suspension pump at the rear shock absorber

The hardness of rear shock absorbers with steel spring can be adjusted by rotating the ring **A**. For more information please refer to the manuals from the suspension manufacturer.

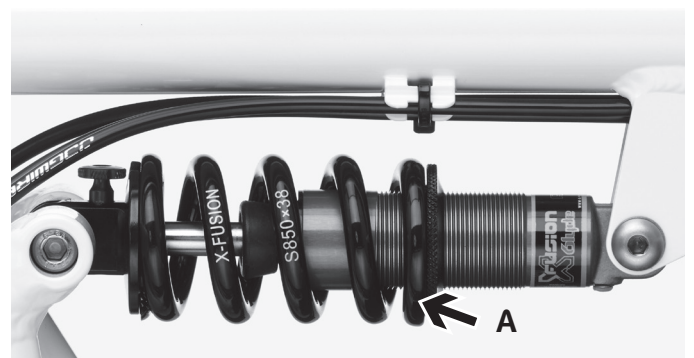

Rear shock absorber with steel spring

## 7. OPERATION

On some E-Bike models you can block the suspension with the lock out levers **B** for rides on smooth ground. If the suspension is blocked out, the E-Bike rides like an "old style" bicycle.

For more information, follow the separately included instructions provided by the suspension manufacturer.

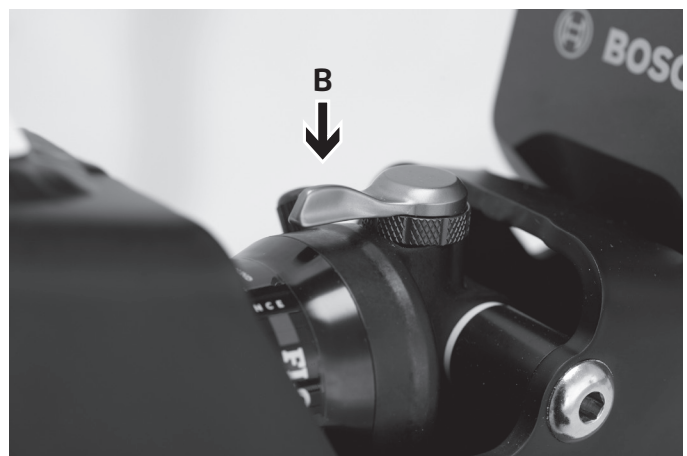

*Lock out levers at front fork and rear shock absorber.*



---

---

## 7.8. INTEGRATED LOCK

Some E-Bikes from Riese & Müller are equipped with a cable lock integrated into the frame.

To use this lock to secure your E-Bike proceed as follows:

1. Pull the lock cable **A** out of the frame.
2. Place the lock cable **A** around a bike rack, fence, sign post or similar.
3. Be careful to not scratch the frame while pressing the end of the cable into the lock **B**.
4. Remove the key **C** from the lock.

The same key is used for the cable lock and the battery lock.

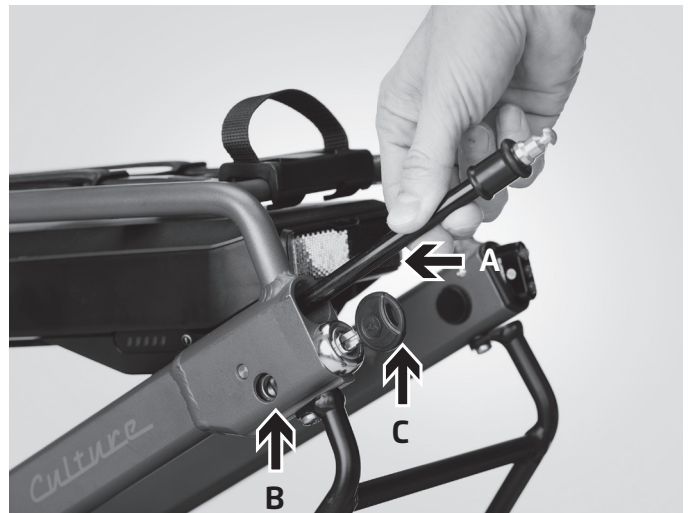

---

## 8. MAINTENANCE AND REPAIRS

---

### 8.1. REGULAR MAINTENANCE

To ensure safe and trouble free operation of your E-Bike, it must be properly maintained and cared for on a regular basis. Please refer to the service and maintenance schedule in section 8.4.2 on page 44 for detailed maintenance guidelines.

Some maintenance can be performed by either you or your authorized dealer. All other maintenance must be carried out by your authorized dealer only.

Refer to the service and maintenance schedule in section 8.4.2 on page 44 where the maintenance intervals specified are based on moderate use of your E-Bike (approximately 300 miles per month). Your E-Bike must be serviced at shorter intervals if you frequently ride in rain, snow or off-road.

Even if you ride it only a few times a year, your E-Bike needs to undergo an inspection at your authorized dealer **once a year**.

### 8.2. INITIAL INSPECTION

A new E-Bike must be inspected after its initial use because screws, shift cables or spokes may have settled a little, making a readjustment necessary. Bring your E-Bike to your authorized dealer after approximately 6 weeks or 300 miles for an initial inspection and any necessary adjustments.

---

---

## 8.3. MAINTENANCE YOU CAN DO BY YOURSELF

### **WARNING**

*Avoid inadvertent activation of the electrical system that may result in injury.*

*Always remove the battery before carrying out any maintenance or other types of work on your E-Bike or before you transport the bike.*

*The electrical assistance starts as soon as the crank arms are moved forward.*

The following is a description of the maintenance that you can perform yourself. Please refer to the service and maintenance schedule in section 8.4.2 on page 44 for detailed maintenance guidelines and maintenance intervals.

### 8.3.1. Cleaning your E-Bike

#### **WARNING**

*Keep brake pads and rotors clean and uncontaminated by any lubricant or wax.*

*Do not apply any care products or lubricant to brake pads, brake discs and the braking surfaces of the rims. The brakes may otherwise fail leading to hazardous situations, accidents and injuries.*

Clean your bike regularly using clear water and a soft cloth or sponge. Do not use any abrasive cleaning agents or high pressure washer as their use may damage surfaces or moving parts.

 *While cleaning, check your E-Bike for any cracks or deformations. If you detect any damage, contact your authorized dealer.*

---

## 8. MAINTENANCE AND REPAIRS

---

### 8.3.2. Brake Inspection

#### 8.3.2.1. Test of setting of the brake levers

To check proper functioning of the brake, pull the brake lever. Make sure you feel a distinct pressure point and that you cannot pull the lever all the way to the grip. Otherwise, the brake needs to be adjusted. For more information on how to adjust the brake, follow the separately included instructions provided by the brake manufacturer. If you cannot readjust the brake lever, you must contact your authorized dealer for assistance.

#### 8.3.2.2. Brake hoses

All Riese & Müller E-Bikes are equipped with hydraulic brakes. Inspect all brake hoses and make sure they have no kinks, damage of any kind and do not leak.

#### 8.3.2.3. Brake rotor

Brake rotors must be free from grease and oil. Contact your authorized dealer if you have any questions regarding the cleaning and care.

### 8.3.2.4. Brake pads

Check the thickness of the brake pads. When worn down to their minimum thickness, the brake pads must be replaced by your authorized dealer.

The pad carrier of the disc brake pads must never touch the brake disc. For more information on the minimum thickness, refer to the separately included instructions provided by the brake manufacturer.

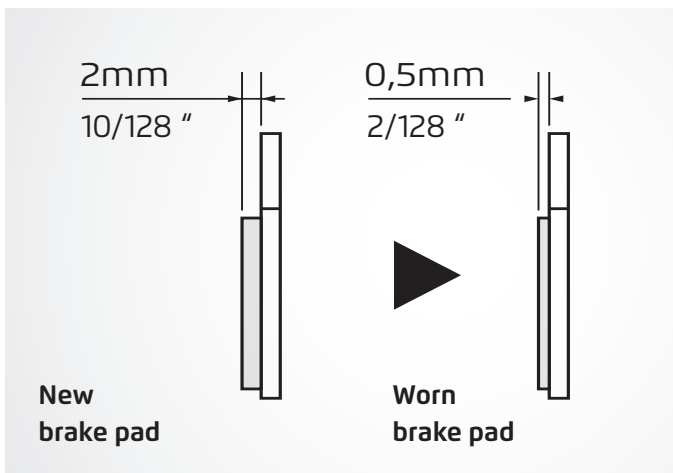

*Minimum thickness of disc brake pads*

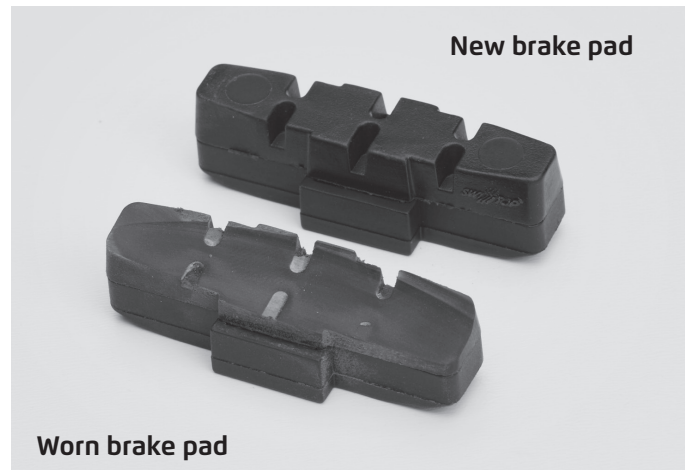

*Minimum thickness of rim brake pads*

### 8.3.3. Headset

Apply the front brake and place the thumb and forefinger of your other hand around the upper headset bearing.

Move your E-Bike forward and backward. If there is play in the bearing, you will notice that the parts of the headset are shifting. If this is the case, the headset bearing must be readjusted by your authorized dealer.



*Checking the headset play*

Lift your E-Bike up at the front until the front wheel is in the air. Move the handlebar to the left and the right. The steering must turn smoothly and without resistance. If the steering is stiff to any noticeable extent, the headset bearing must be repaired by your authorized dealer.

---

## 8. MAINTENANCE AND REPAIRS

---

### 8.3.4. Chain

Make sure to clean and lubricate the chain at least every 300 miles. After riding in the rain, it might be necessary to lubricate the chain more frequently. Purchase a suitable lubricant from your authorized dealer.

Check the chain tension on E-Bikes with gear hubs. Try to move the chain up and down in the center between the front and the rear sprockets. If the chain can be deflected by more than  $\frac{3}{4}$ ", bring your E-Bike to your authorized dealer to retighten or replace the chain.

### 8.3.5. Belt drive

Perform an inspection of your belt for visible damage every 300 miles.

For more information refer to the separately included manual supplied by Gates.

### 8.3.6. Tires

#### **WARNING**

***Avoid accidents, falls and serious injuries.***

***Do not overinflate or underinflate your tires.***

***If the tire pressure is too low or too high, the tire may burst or detach from the rim.***

Check the air pressure once a month using an air pump with gauge. You will find the minimum and maximum pressure on the sidewall of the tires (see section 5.5 on page 22). The air pressure in the tire must be greater than the minimum value and not exceed the maximum value.

Check the tires for wear, tear or damage and true running. A worn tire will provide less traction on wet or dirty ground. It is also less puncture resistant. Only your authorized dealer may change the tires.

E-Bikes from Riese & Müller are equipped with OEM tires that are highly puncture-proof.

 *For questions regarding the repair of a puncture, contact your authorized dealer.*

### 8.3.7. Wheels

On E-Bikes equipped with rim brakes the rim is subject to wear.

Check whether the wear indicator **A** is visible along the entire length of the left and right sidewalls of the rim.

Check whether the rims are damaged or deformed. If this is the case, the damaged or worn rims must be replaced by your authorized dealer.

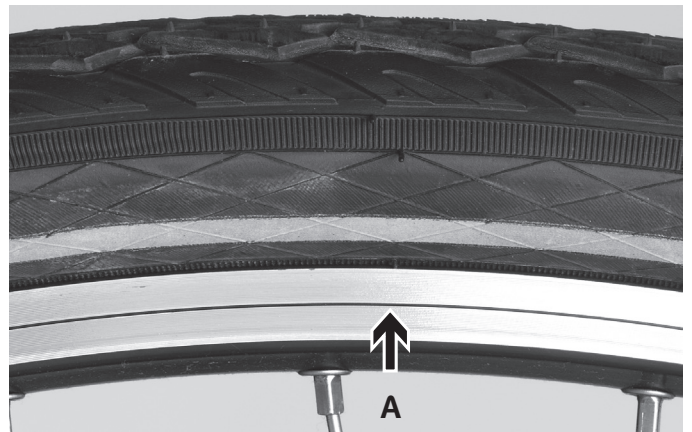

*Wear indicator*

Rims must be free from grease and oil. If you have any questions regarding cleaning, contact your authorized dealer.

Check whether the rims are running true.

To do so, lift the wheel off the ground and spin the wheel with your hand.

Hold an object (e.g. pen) up close to the rim. Check whether the rim is running true.

If the rim is noticeably out of true and wobbles, contact your authorized dealer. He must true the wheel.



*Wheel running true check*

---

## 8. MAINTENANCE AND REPAIRS

---

### 8.3.8. Suspension

Refer to and follow the instructions provided in the separately included manual supplied by the suspension manufacturer.

Check the suspension fork and the rear shock and make sure that there is no oil leaking.

In any case of leakage you must contact your authorized dealer.

Use the included suspension fork pump to check the air pressure in the air suspension elements to be sure that the pressure has not changed since the last time it was checked.

If the pressure has changed, use the pump to renew the pressure.



*Oil leakage at the fork*

Squeeze and release the suspension fork while applying the front brake. Squeeze and release the rear shock by leaning yourself on the saddle and then getting off. If you can clearly hear or feel play in the suspension, you must contact your authorized dealer to inspect the suspension.

### 8.3.9. Lighting

Check the setting of the headlight. The headlight must not be set too high so as not to blind on-coming traffic. The headlight must not be set too low because otherwise you will not be able to see far enough in the dark. For details on how to adjust the headlight, refer to section 5.7 on page 24.

Check the tail light for tight fit.

 *For questions regarding legal compliance of your E-Bike with all applicable state and local laws regarding lighting, please contact your authorized dealer.*



---

---

## **8.4. MAINTENANCE THAT MUST BE CARRIED OUT BY YOUR AUTHORIZED DEALER**

All maintenance that requires the use of special tools or professional expertise shall be performed only by your authorized dealer and is marked with an “x” in the service and maintenance schedule in section 8.4.2 on page 44.

### **8.4.1. Changing and replacing components**

The components fitted on your Riese & Müller E-Bike have been designed to complement one another. Some of these parts have been dimensioned specifically to fit E-Bikes.

If any of these components are worn or damaged, make sure that they are replaced by your authorized dealer with the same components or components of similar quality, strength and durability.

---

## 8. MAINTENANCE AND REPAIRS

---

### 8.4.2. Service and maintenance schedule

If the inspection reveals defects immediate action is necessary.

For questions and concerns, please contact your authorized dealer.

<b>PART</b>	<b>STEP</b>
Lighting	Check function and secure fit
Tires	Check air pressure
	Check for damage, uneven or not true running
	Verify minimum tread depth and check for damage
Brakes	Check lever stroke, pad thickness and pad position relative to the brake surface
	Check all fittings / connections
Brake lines	Visual inspection for leakage
Brake rotors	Check thickness
Suspension fork	Check for play and leakage
	Clean and lubricate
Rear shock absorber	Check for play and leakage
	Clean and lubricate
Rear swing arm	Check function and bearing play
Rims	Check true running
	Check wear indicator
Wheels	Check true running
	Check spoke tension, retighten axle nuts
Chain	Clean and lubricate
	Check wear and replace if necessary
Belt drive	Check wear, replace if necessary
Pedals	Retighten fitting, check bearing play
Chainwheel, sprocket	Check wear and replace if necessary
Handlebar, stem	Visual inspection
	Replace
Handlebar grips	Check secure fit
Headset bearings	Check bearing play
	Re-lubricate
Hubs	Check bearing play, lubricate
Hub gear	Check function
Saddle clamp	Retighten fitting
Seatpost	Clean, lubricate seat tube
Switchgear	Clean, lubricate, check function
Quick releases, thru axles	Check secure fit
Screws and nuts	Check secure fit
Mudguard mount	Check secure fit
Shift cables	Check function / replace

- Service and maintenance steps can be carried out by you as long as you have the technical skill and the proper tools such as a torque wrench.
- ✘ Work shall be carried out by your authorized dealer during the annual inspection.

BEFORE EVERY RIDE	MONTHLY	ANNUALLY	OTHER INTERVALS / REMARKS
•			
•			
•			
	•		Min. thread depth: 1 mm
•		✘	
•			✘ After every second replacement of the brake pads.
	•		✘ See specification of the suspension manufacturer.
	•		✘ See specification of the suspension manufacturer.
		✘	
•			
	•		
•			
		✘	
	•		After riding in rain Every 1,000 km / 600 miles
		✘	
		✘	
		✘	Every 1,000 km / 600 miles
		✘	
			✘ After a fall, 12,500 miles / 20,000 km or 5 years, whichever occurs first
		•	
	•		
		✘	Not necessary for cartridge bearings
		✘	
		✘	
		✘	
		✘	
	•	✘	
•			
		✘	
	•	✘	
		✘	

## 8. MAINTENANCE AND REPAIRS

### 8.4.3. Torque Settings

PART	FITTING	TORQUE ft.lb / Nm
Coaster brake arm	Mounting screw	35–53 / 4–6
Brake lever	Mounting screw	44–53 / 5–6
Rear shock absorber	Mounting screw	62–80 / 7–9
Freewheel	Sprocket cassette lock ring	256–433 / 29–49
Delite carrier	Mounting screw	71–88 / 8–10
Swingarm bushing	Locking screw	44 / 5
Hydraulic brakes	*)	
Crankset	Crank bolts	310 / 35
	Chainring bolts	71–97 / 8–11
Rear hub	Axle nut Shimano gear hub	265–398 / 30–45
	Axle nut Nuvinci gear hub	265–354 / 30–40
	Axle nut Rohloff gear hub	265–310 / 30–35
Pedals		310 / 35
Kickstand	Mounting screws	88–106 / 10–12
Rohloff gears	*)	
Tail light	Mounting screws	88–106 / 10–12
Seat post	Saddle clamp	*)
	Seatpost clamp	80–106 / 9–12
Shifter	Derailleur shifter mounting screw	35–44 / 4–5
	Twist shifter mounting screw	9–18 / 1–2
Derailleur	Mounting screw	71–88 / 8–10
	Cable fixing screw	35–53 / 4–6
	Guide pulley bolts	27–35 / 3–4
Mudguards	All mounting screws	27–35 / 3–4
A–Headset stem	Handlebar clamp with 4 screws	**)
	Stem clamp bolt	**)
Bosch system	*)	44–53 / 5–6

\*) see the separate enclosed manual of the component manufacturer

\*\*\*) see marking on component

---

---

#### 8.4.4. Torque Settings for E-Cargo Bikes

<b>PART</b>	<b>FITTING</b>	<b>TORQUE ft.lb / Nm</b>
Frame	Connection front/rear frame 4 x M10 screws	265–354 / 30–40
	Connection front/rear frame 2 x M8 screws	177–221 / 20–25
Front fork	Steerer clamp above the headset 2 screws	106–124 / 12–14
	Clamp for steering rod at right stanchion 4 x M5 screws	44–53 / 5–6
Steering linkage	Front and rear steering linkage 2 x M6 screw and nut	80–106 / 9–12
Kickstand	Counter nuts M8	106–124 / 12–14
	Eye bolts and M5 nuts for kickstand spring	44–53 / 5–6

#### 8.4.5. Torque Settings for adjustable Stems

<b>PART</b>	<b>FITTING</b>	<b>TORQUE ft.lb / Nm</b>
Clamp stem to steerer	4 clamping screws M6	62–80 / 7–9
Angle adjustment	2 front clamping screws M6	62–80 / 7–9
	2 rear clamping screws M5	27–35 / 3–4
	2 set screws at quick release levers	9 / 1

---

## 9. WARRANTY TERMS AND CONDITIONS

---

### TWO (2) YEAR LIMITED WARRANTY

NOTICE: THIS TWO (2) YEAR LIMITED WARRANTY GIVES YOU CERTAIN RIGHTS. PLEASE READ THE FOLLOWING CAREFULLY. ALL RIGHTS NOT EXPRESSLY GRANTED ARE RESERVED BY THE MANUFACTURER (RIESE & MUELLER GMBH).

The manufacturer provides a limited warranty and warrants its products and/or components and accessories that were purchased from an authorized dealer in and for use in the Fifty (50) United States of America, the District of Columbia or Puerto Rico and Canada, to be free from defects in material and workmanship from the date of purchase of the product for the following time period:

**Two (2) Years**

**For the warranty to be effective, the purchaser must register the purchase of the E-Bike online at: [www.r-m.de/en-us/service/warranty](http://www.r-m.de/en-us/service/warranty)**

Upon registration of the purchase of the E-Bike with RIESE & MUELLER, the frame and swing arm will be covered against breakage by an additional 3 years of warranty for a total warranty period of Five (5) years from the date of purchase.

The Lithium-Ion Battery Pack „Power Pack“ is guaranteed to have at a minimum 60% of its nominal capacity after 500 (five-hundred) full charging cycles or after 1 (one) year counted from the date of purchase by the original purchaser.

Parts and components that are not manufactured by RIESE & MUELLER GMBH and their future availability, are warranted as determined by the respective manufacturers and set forth in the respective manufactures warranty terms and conditions.

THIS LIMITED WARRANTY IS IN LIEU OF ANY OTHER WARRANTIES, EXPRESS OR IMPLIED, INCLUDING ANY IMPLIED WARRANTY OF MERCHANTABILITY OR FITNESS FOR A PARTICULAR PURPOSE, USE OR OTHERWISE, AND OF ANY OTHER OBLIGATIONS OR LIABILITY ON THE MANUFACTURER'S PART.

This warranty applies only to the original retail purchaser and is not transferable from the original purchaser to subsequent purchasers.

This warranty applies only to RIESE & MUELLER E-Bikes purchased from an authorized dealer.

---

THIS LIMITED WARRANTY IS ONLY VALID AND AVAILABLE IN AND ONLY IF THE PRODUCT HAS BEEN PURCHASED FROM AN AUTHORIZED DEALER IN AND FOR USE WITHIN THE FIFTY (50) UNITED STATES OF AMERICA, THE DISTRICT OF COLUMBIA AND PUERTO RICO AND CANADA.

**This warranty does not cover ordinary wear and tear on some components, including, but not limited to the chain-drive, belt-drive, brakes, grips, shifting cables, tires, and saddle.**

**This warranty does not cover paint, decal and finish.**

This warranty does not cover damage to the product or damage caused to other equipment if caused in whole or in part by:

- Improper use or handling.
- Accident, misuse, abuse or neglect.
- Modification of the E-Bike
- Installation of components, parts or accessories not originally intended for or compatible with the E-Bike as sold.
- Improper assembly.
- Failure to properly maintain the E-Bike.
- Failure to have the E-Bike serviced at the intervals set forth in this manual.

This warranty does in general not cover labor charges if any covered parts or components need to be replaced. RIESE & MUELLER reserves the right of refunding labor costs individually at its own discretion.

This warranty is void in its entirety in case of any modification or alteration of the frame, fork or any of the components of the E-Bike unless such modification has been approved in advance in writing by the manufacturer (RIESE & MUELLER).

In the event of a defect in material or workmanship during the respective warranty periods specified above, from the date of purchase of the product, the manufacturer will, at the manufacturer's sole discretion, repair or replace the product and/or any defective parts, components or accessories on the terms and conditions and with the limitations and exclusions as set forth below.

**If there are problems with the product and/or any of its components or accessories, contact your authorized dealer. All warranty claims must be processed through an authorized dealer. Proof of purchase (copy of the invoice) is required for all warranty claims.**

---

## 9. WARRANTY TERMS AND CONDITIONS

---

Defective parts or components will be repaired or replaced with new or reconditioned parts or parts of similar design, as the manufacturer in its sole discretion may decide.

Any replaced parts become the property of the manufacturer and the manufacturer is free to discard them.

If it is determined that no warranty coverage is available either because the coverage period has passed or, for example, if the defect is due to improper use or lack of maintenance, use of non-OEM spare parts or any other not covered causes as set forth above, your authorized dealer will inform you and give you an estimate for the necessary repair(s).

Any repairs and/or exchanges performed under this limited warranty do not extend the warranty period beyond the respective time limits set forth above.

This limited warranty shall be null and void in case of abuse, neglect, accident, acts of God, disaster, misuse, mishandling, improper installation, improper operation, unauthorized repair or modification, use of non-proprietary, after market or non-OEM spare parts, or failure to follow the manufacturer's instructions with respect to the proper installation, handling, operation, service and maintenance of the product as outlined in this manual.

THIS LIMITED WARRANTY IS LIMITED TO THE REPAIR OR REPLACEMENT OF THE PRODUCT AND/OR ITS COMPONENTS OR PARTS.

THIS LIMITED WARRANTY IS IN LIEU OF ANY OTHER WARRANTIES, EXPRESS OR IMPLIED, INCLUDING ANY IMPLIED WARRANTY OF MERCHANTABILITY OR FITNESS FOR A PARTICULAR PURPOSE, USE OR OTHERWISE, AND OF ANY OTHER OBLIGATIONS OR LIABILITY ON THE MANUFACTURER'S PART.

NOTWITHSTANDING THE PREVIOUS SENTENCE, ANY IMPLIED WARRANTY OF MERCHANTABILITY OR FITNESS FOR A PARTICULAR PURPOSE OF THIS PRODUCT IS LIMITED TO THE TWO (2) YEAR DURATION PERIOD OF THIS WRITTEN WARRANTY AS SET FORTH ABOVE, OR FIVE (5) YEARS FOR THE FRAME AND SWING ARM AS SET FORTH ABOVE.

HOWEVER, SOME STATES DO NOT ALLOW LIMITATIONS ON HOW LONG AN IMPLIED WARRANTY LASTS, SO IN SUCH STATES THE ABOVE LIMITATION(S) MAY NOT APPLY TO YOU.

IF THIS PRODUCT IS DEFECTIVE, YOUR ONLY REMEDY IS REPAIR OR REPLACEMENT, AS DESCRIBED ABOVE.



---

---

TO THE MAXIMUM EXTENT PERMITTED UNDER APPLICABLE LAW, IN NO EVENT AND UNDER NO CIRCUMSTANCES WILL THE MANUFACTURER, ITS DISTRIBUTORS, DEALERS OR THEIR AGENTS BE LIABLE FOR ANY SPECIAL, INCIDENTAL, INDIRECT, PUNITIVE OR CONSEQUENTIAL DAMAGES, INCLUDING BUT NOT LIMITED TO ANY LOST PROFITS, LOST COMPENSATION OF ANY KIND, BUSINESS INTERRUPTION, DOWN TIME, OR ANY OTHER DAMAGES CAUSED BY THE MANUFACTURER'S BREACH OF WARRANTY, NEGLIGENCE OR BREACH OF CONTRACT.

TO THE MAXIMUM EXTENT PERMITTED UNDER APPLICABLE LAW, IN NO EVENT AND UNDER NO CIRCUMSTANCES WILL THE MANUFACTURER, ITS DISTRIBUTORS, DEALERS OR THEIR AGENTS BE LIABLE FOR ANY SPECIAL, INCIDENTAL, INDIRECT, PUNITIVE OR CONSEQUENTIAL DAMAGES, INCLUDING BUT NOT LIMITED TO ANY LOST PROFITS, LOST COMPENSATION OF ANY KIND, BUSINESS INTERRUPTION, DOWN TIME, OR ANY OTHER DAMAGES CAUSED BY THE USE OF THIS PRODUCT OR INABILITY TO USE IT, EVEN IF THE MANUFACTURER, ITS DISTRIBUTORS, DEALERS OR THEIR AGENTS HAVE BEEN ADVISED OF SUCH LIABILITY CLAIMS OR OTHER CLAIMS OR THE POSSIBILITY OF SUCH CLAIMS OR OTHER CLAIMS.

SOME STATES DO NOT ALLOW THE EXCLUSION OR LIMITATION OF INCIDENTAL, CONSEQUENTIAL OR OTHER DAMAGES, SO THE ABOVE LIMITATION OR EXCLUSION MAY NOT APPLY TO YOU.

THIS WARRANTY GIVES YOU SPECIFIC RIGHTS, AND YOU MAY HAVE OTHER RIGHTS WHICH MAY VARY FROM STATE TO STATE.

---

## 10. INFORMATION REGARDING PARTS THAT ARE SUBJECT

---

Some parts of your E-Bike are subject to wear and tear due to the function they perform.

The degree of wear and tear varies with the degree of care and maintenance given to the E-Bike as well as the usage to which your E-Bike was exposed (mileage, rides in rain, dirt, salt, etc.).

E-Bikes that are frequently parked outdoors may show increased wear and tear due to weather impact.

The following parts must be replaced upon reaching their wear limit:

- The drive chain/belt
- The brake cables
- The rubber on the grips
- The chain wheels, sprockets or belt pulleys.
- The shifter cables
- The tires
- The saddle
- The brake pads
- The rims

---

## TO WEAR AND TEAR

---

Your exclusive contact for complaints and customer service requests is an authorized Riese & Müller dealer.

We will be happy to provide the name and contact information of the authorized dealer that is closest to you. Or, you can find a list of authorized dealers at [www.r-m.de](http://www.r-m.de).

If you need any repair of your Riese & Müller E-Bike you should contact your authorized dealer right away to schedule the repair to make sure that your repair will be handled in the quickest and most cost-effective way.

To ensure the longest possible lifespan and durability of the components, you must strictly adhere to the installation instructions of the manufacturer (including the torque to be applied to screws at sections 7.4.3 through 7.4.5., beginning on page 46 and the specified maintenance intervals.

Failure to observe the installation instructions and maintenance intervals may render the warranty void and absolve the manufacturers from liability for defects.

---

# 11. E-BIKE PASSPORT

---

All inspections listed in section 11.3. must have been conducted and recorded by your authorized dealer. Fill in form 11.1 together with your authorized retailer.

Confirm the compliance with the delivery process according to chapter 11.2. with your signatures.

## 11.1. E-BIKE DATA

---

Model:

---

Color:

---

Number of gears:

---

Frame number:

---

Battery number:

---

Purchase date:

---

Dealers stamp:

---

Delivery and handover of the E-Bike to the customer made according to section 11.2.:

Customer:

Dealer:

---

---

---

## 11.2. DELIVERY RECORD

Dear Authorized Dealer, dear Customer,

Please study the delivery record below together. Both dealer and customer shall confirm the review of this document with their signatures. The Authorized Dealer shall provide the customer with a copy of this delivery record.

ITEM	DONE?
Hand over the invoice to the customer; the invoice must include the date of purchase, the exact designation of the E-Bike, including frame size, frame number, Bosch display number and battery number(s).	<input type="radio"/>
Adjustment of the saddle height to fit the customer. For E-Bikes with quick releases on the seat post: explanation on how to set the appropriate saddle height.	<input type="radio"/>
Adjustment of the handlebar and of brake grips and grip shifters to fit the customer.	<input type="radio"/>
Explanation to the customer on which brake lever operates the front brake and reversing the brake cables if so desired by the customer.	<input type="radio"/>
For E-Bikes with adjustable stem: Adjustment of the stem to fit the customer and explanation of the adjusting mechanism.	<input type="radio"/>
Adjustment of the suspension to fit the customer and explanation of its operation.	<input type="radio"/>
Explanation to the Customer of the control elements of the electric drive system and with the gears and confirmation by the Customer that he/she fully understands these control elements.	<input type="radio"/>
Explanation on how to operate quick releases and wheel attachment.	<input type="radio"/>
Customer has been provided with all instruction manuals that come with the E-Bike. List of manuals:	<input type="radio"/>
1. _____	6. _____
2. _____	7. _____
3. _____	8. _____
4. _____	9. _____
5. _____	10. _____
Customer has received instructions by the authorized dealer on how to use the E-Bike as intended.	<input type="radio"/>
Customer has been given information on the maximum permitted gross weight.	<input type="radio"/>
Customer has completed a test ride.	<input type="radio"/>
Customer has been instructed to carefully familiarize themselves with the brakes in a traffic-free area.	<input type="radio"/>

Signature Dealer:

Signature Customer:

.....

.....

---

# 11. E-BIKE PASSPORT

---

## 11.3. SERVICE RECORD

<b>1<sup>st</sup> Inspection</b> Within 6 weeks of purchase or within the first 300 miles.	Replaced or repaired parts:
Order number:      Date:	
Stamp / Signature of dealer:	
<b>2<sup>nd</sup> Inspection</b> Within 1 year of purchase or within the first 1,250 miles:	Replaced or repaired parts:
Order number:      Date:	
Stamp / Signature of dealer:	
<b>3<sup>rd</sup> Inspection</b> Within 2 years of purchase or within the first 2,500 miles:	Replaced or repaired parts:
Order number:      Date:	
Stamp / Signature of dealer:	
<b>4<sup>th</sup> Inspection</b> Within 3 years of purchase or within the first 3,750 miles:	Replaced or repaired parts:
Order number:      Date:	
Stamp / Signature of dealer:	

---

<b>5<sup>th</sup> Inspection</b> Within 4 years of purchase or within the first 5,000 miles:	Replaced or repaired parts:
Order number:      Date:	
Stamp / Signature of dealer:	

<b>6<sup>th</sup> Inspection</b> Within 5 years of purchase or within the first 6,250 miles:	Replaced or repaired parts:
Order number:      Date:	
Stamp / Signature of dealer:	

<b>7<sup>th</sup> Inspection</b> Within 6 years of purchase or within the first 7,500 miles:	Replaced or repaired parts:
Order number:      Date:	
Stamp / Signature of dealer:	

<b>8<sup>th</sup> Inspection</b> Within 7 years of purchase or within the first 8,750 miles:	Replaced or repaired parts:
Order number:      Date:	
Stamp / Signature of dealer:	





© 2017, Riese & Müller GmbH

Text and concept  
Riese & Müller GmbH

Graphic design  
[www.wolf-corporate.de](http://www.wolf-corporate.de)

Photography  
Kay Tkatzik, Riese & Müller GmbH

State 03/2017, 170448

# RIESE & MÜLLER

---

Riese & Müller GmbH  
Feldstraße 16  
64331 Weiterstadt  
Germany

---

team@r-m.de  
www.r-m.de  
Tel.: +49 61 51-366 86-0  
Fax: +49 61 51-366 86-20

---



Scan the QR code with your smartphone to get direct access to all actual instruction manuals. Or visit our website: [www.r-m.de/en-us/service/downloads/](http://www.r-m.de/en-us/service/downloads/)

---